

THE CARRIER PIGEON



BULLETIN OF BALLINA CLASSIC VEHICLE CLUB INC.

ISSUE NO. 408

AUGUST 2023

NEWSFLASH

Our Classic Vehicle Club has introduced a new “photo system” for car and bike registration. The three photos are to include... engine bay, three-quarter view and rear view. **Obviously....** some club members are having trouble with the interpretation of what’s needed!



For a report and instructions on what’s actually needed..... Refer to page 9



PRESIDENT:

Lindsay Smith
Email: lgsmith@pigpond.com
Phone: 0438 448 816



VICE PRESIDENT:

David Felcsh



SECRETARY:

Dianne Vickery
Email: newdipie1@gmail.com



TREASURER:

Russell Kelly



CLUB REGISTRAR:

Santo Pennisi
Phone: 0427 299 338

PLEASE SUBMIT ALL
ARTICLES, PHOTOS AND
CONTRIBUTIONS FOR
THE CARRIER PIGEON TO
THE EDITOR.

ALL OTHER CLUB
CORRESPONDENCE TO
THE SECRETARY.



CLUB MEETINGS:

1st Tuesday of the month,
7pm sharp,
Ballina RSL Club.



AUTO PARTS STORE

6/46 De Havilland Crescent, Ballina

DO YOU NEED PARTS?

Purchase your parts at
B-Line Auto through the
club cash account to
receive trade pricing
just show your membership card

FROM THE EDITOR

Firstly, corrections from last months edition

The last printed edition of the Carrier Pigeon was issue 406. The first new edition should of been 407 (not 406) making this edition 408.

Some incorrect spelling on names: Russell Kelly, Geoff Buggie, Greg Lofts, Garry Legge

and incorrect email address: Lindsay Smith lgsmith@bigpond.com

Apologies to all (Ed. still on learners plates)

Thanks to those who have contributed to your clubs bulletin.

The last bulletin included various challenges (eg. Do you know your early Mazda's and Toyota's) - we would like to know how your answers faired.

Trust the next month is kind to you all.

Happy and Safe Motoring

Mark Prowse, Editor



EDITOR:

Mark Prowse

madac200@bigpond.net.au

Phone: 0437 873 661



**We need
your input**

PRESIDENT'S NATTER

Congratulations to Mark on the recently launched Club Bulletin! Edition 1 was popular with members who read it. Hopefully we can get it emailed out to all members and will get some printed for those members without the internet. It should also appear on our club website in future if possible. Edition 402, as it is officially numbered, has a great variety of information to interest club members and I look forward to the next edition.

The Bulletin is really only as good as the contributions provided to the Editor so please assist him by considering what article you can contribute. I would like to think every member can contribute an article over the club year whether it be about your first car you ever owned, current classic in your garage, best tooly ou ever purchased, best roadtrip or cars you would like to own one day.

There was a club run on Sunday August 27th to the Brunswick Heads Bowling Club for lunch. Club runs are an opportunity to get out of the house, run the classic, see other nice cars and have some good food and friendship so please consider.

I am looking at a President's Run in November for those who like a weekend away and more information soon.

Any members who have ideas for club runs get in touch with Cedric or Therese or send me an email and I can pass it on. Events, collections or garage crawls are all OK and some will appeal to different members but it is also a chance to invite other car clubs in the area along.

See you at the meeting

Lindsay



LADIES PAGE

If your husband were a car, what kind of car would he be? (and why?)

A 1959 Black Ferrari that's more trouble than what it's worth!

What's the best or worst road trip you've ever taken in a car or bike.

A road trip with Mark and Debra Prowse and another couple in 2016 around the North Island of New Zealand. Great company, fantastic scenery and lots of coffee and cake stops.

If you could invent a vehicle that could run on any substance as an alternative fuel, no matter how crazy, what would it be?

Radish juice. Quick to grow, easy to harvest and can be grown all year round in Australia.

If you had a race car, what brands / products would you have painted across the exterior as sponsors?

Haigh's Chocolates. An Australian owned company that makes the most delicious chocolate treats. I'd make sure I receive a never ending supply. Secondly, Jenny Craig.



Maria Pennisi



Lyn Duncan

If your husband were a car, what kind of car would he be? (and why?)

Stephen would be a 1950's Cadillac as it is reliable, can be stylish and formal on special occasions, yet always voluptuous & soooo comfortable.

What's the best or worst road trip you've ever taken in a car or bike?

Back in the dreamtime, Steve and I were members of the Vintage & Veteran Chevrolet Association of Australia (VVCAA) with a stunning, baby-kack yellow 1939 Chevrolet. To celebrate a significant milestone within the Club, the ladies decided to expand the details of a celebratory Parramatta to Bathurst Weekend Run. Each family participating in the Weekend Run had to dress in clothing styles similar to the era of their vehicle during the day, plus evening function at Bathurst City Hall Saturday night. The ladies were sent scurrying to OP Shops and / or grandparent's wardrobes searching for bags, shoes, hats, coats and gowns generating so much conversation within the Club

focussing on --- "I haven't a thing to wear!". The men designed a Road Trivia for the children to complete during the long drive, as well as giving the vehicles a thorough wash & polish...what a head-turning procession leaving Parramatta Park that day. Fun? --- ohhh yes!

If you could invent a vehicle that could run on any substance as an alternative fuel, no matter how crazy, what would it be?

An expensive, excellent, quality Margaret River Chardonnay --- I'm not considering any old stuff! --- I want to be always prepared if the car breaks down in the desert!

If you had a race car, what brands / products would you have painted across the exterior as sponsors?

1. Spotlight 2. Dan Murphy's 3. Best & Less 4. Swifty's Seafood Shop, Lismore 5. NRMA Roadside Assist 6. Wallet Wizard!

If your husband were a car, what kind of car would he be? (and why?)

A Land Cruiser - Hard working, reliable and heavy duty.

What's the best or worst road trip you've ever taken in a car or bike.

Up to Bangalow on the back of Mark's Matchless motorbike. My bum was numb.

If you could invent a vehicle that could run on any substance as an alternative fuel, no matter how crazy, what would it be?

Sea water. We are being told there will be plenty of it.

If you had a race car, what brands / products would you have painted across the exterior as sponsors?

Versace, Louis Vuitton, Dior, Guicci, Channel, Hermes



Debra Prowse

HJ60 LAND CRUISER AND CASTRO SHIRT BY TOM SILVER

The car is a 1985 HJ60 Land Cruiser that mum and dad bought new in 1986 from Pennant Hills Toyota. It eventually became my sister’s first car before being passed onto me.

It is a naturally aspirated diesel auto, so to say it lacks power is a bit of an understatement! Having said that, dad still tells me about how quiet and smooth they thought it was when first purchased, not to mention push button 4WD and central locking!

We joke that dad was the first of the Sydney north shore ‘yuppies’ to buy a 4WD, though they did do a lot of camping. Previous to the cruiser they’d owned an International Scout, and a Jeep CJ8 that they modified to compete in the 1985 Wynn’s Safari. Up till then dad had owned and unfortunately sold a few classics, including a HK Monaro, a Porsche 911s and one of the last chargers off the assembly line.



It may not be the most historic or valuable car in the club, but it has a lot of sentimental value for our family and it’s great being able to keep it on the road.

Ed. Tom’s wearing the Castrol T shirt he took home, as the lucky door prize at the last meeting.

DO YOU KNOW YOUR BITS AND PIECES?

- | | |
|---|--|
| <p>1. What do you call the part that holds up a exhaust
.....</p> <p>2. What is the name of the fuel/ air ratio used for complete gasoline fuel combustion?
.....</p> <p>3. What is the name of the plastic part at the end of a shoelace?
.....</p> <p>4. What does the word “automobile” mean? .
.....</p> <p>5. What is the tip of an umbrella called?
.....</p> <p>6. What is the name of the first petrol car made in Australia?
.....</p> <p>7. What animal is on the Porsche logo?
.....</p> | <p>8. What are the dots on a dice called?
.....</p> <p>9. What is the hotness scale for chilli peppers called?
.....</p> <p>10. Ralph Teetor was a blind mechanical engineer who created what car feature?
.....</p> <p>11. What is the shape of Wombat poop?
.....</p> <p>12. What luxury car brand has a “Spirit of Ecstasy” hood ornament?
.....</p> <p>13. What is the recommended crosshatch angle, to the horizontal surface, when honing a motor cylinder ?
.....</p> |
|---|--|

Answers:

1. Insulator 2. Stoichiometric Ratio 3. an Angle 4. Auto=Self, Mobile=Moving 5. Ferrule 6. Tarrant.....(1897) 7. Horse 8. Pips 9. Scoville Scale 10. Cruise Control 11. Cube 12. The Rolls-Royce 13. 22 to 32 degrees

BARN FINDS

Dino buried in a Los Angeles yard

In December 1974, a California man reported his two-month old Ferrari Dino 246GTS stolen. According to the police report, the car had vanished without a trace – and, because the story checked out, the owner claimed the insurance money.

Some four years later, two boys playing in the dirt in their backyard hit something metallic. Further digging revealed a car roof and, when the police arrived, the missing Dino was exhumed – and it was remarkably well-preserved, all things considered.

The car's next owner restored it and it's still on the road today, wearing a vanity plate that reads DUG UP – no joke.

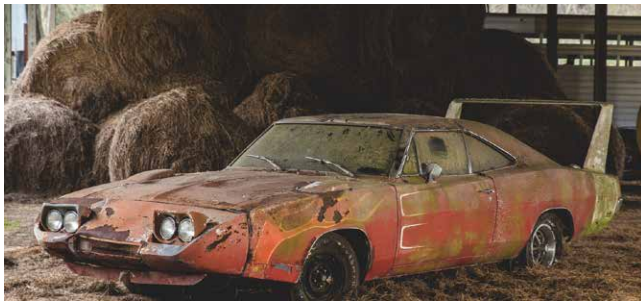

Dodge Charger Daytona in an Alabama barn

When car restorer Charlie Lyons visited Glenwood, Alabama, with a view to buying a 1970 Chevelle, the last thing he expected to come across was a rare 1969 Dodge Charger Daytona – a car developed to win NASCAR races and built to the tune of just 503 examples.

Porsche 901 in a Brandenburg barn

Porsche's 911 might have been called the 901 had it not been for a copyright complaint by Peugeot. So it was that the Stuttgart legend became the 911 – but not before 82 were built with 901 designation in 1964.

None were officially sold to the public and they're so rare that even the Porsche factory didn't have one in its collection.



Ferrari 166MM in the Arizona sun

One of the earliest Ferrari models – and arguably the car that made Ferrari – this 1950 Ferrari 166MM Barchetta started out in Europe as one of only 25 built.

A man called Reg Lee Litton reportedly asked a friend to buy the car for him and had it shipped out to California. Alas, at some point thereafter something broke, so the Barchetta was laid up in his yard and left open to the Arizona elements for decades.

Eventually the 166MM was discovered and sold – but by then the seller was clued up, so California-based Manny Del Arroz paid more than US\$1m for it, even in its barn-find state.

Land-Rover #1

'JUE477' isn't quite the first ever Land-Rover – a prototype and 48 pre-production models pre-date it – but it is the first one intended for public consumption and is therefore a pivotal vehicle in the Landie story.

It was very nearly lost to history, though, having been rescued from its resting place in a Northumberland barn a few years ago.

'Juey' changed hands in late 2017, following its recovery, and despite appearances will be put back on the highway.



1963 DB4 Convertible discovered

Arguably one of the most beautiful cars of all time, the Touring-styled DB4 launched in 1958 and set the tone for Aston Martin machines for the next 25 years.

Conventionally available as a coupé, just 70 were built in convertible guise – including the 1963 example unearthed at the start of this decade

Sole-surviving WO Bentley 4½ Litre Vanden Plas Tourer

It was auctioned by H&H Classics in March 2019 and fetched an impressive £454,250 – which is all the more remarkable when you consider that the previous time it had been sold it had gone for the princely sum of £260!



Lightweight E-type lost then found

When, in 1998, Jaguar specialist Terry Larson heard rumours about an alloy-bodied E-type coming out of the estate of renowned pilot Howard Gidovlenko – the 'Mad Russian' – he jumped on the first plane to LA.

Buried beneath boxes and household junk in a lock-up Larson found one of the rarest E-types, the last missing Lightweight example – chassis S850660, the third built and raced at Sebring in 1963.

Gidovlenko had begun preparing it to race in 1964 but never finished, and its engine and gearbox had been removed and rebuilt, while the owner's old helmet and even the original bill of sale were with the car.

It sold at auction in 2003 for \$1.3m.

MY Mechanic

Lic. No. MVRL 45955

Repairs • Service • Rego Checks

Adam Prowse

Ph: 66 866 111

2/256 River St. Ballina 2478, NSW

Adam supports the Club
with "lucky door prizes"
for our meetings.
Thanks Adam

PLAYING WITH OLD CARS

I started to take an interest in cars at about 15 with 2 mates { John Reid & Lee Holder} who I started school with. Our main interest back then was Hot Rods as an older person who lived not far from us was building a 1934 channelled ford coupe with motor cycle guards, this was very early in Australian hot rodding. We first managed to get an old Triumph motor bike engine to play with, next we managed to get a side valve V8 motor off a stock car racer Bill Johnson who had heaps of motors laying around.

Our next project was an unregistered 1936 Ford sedan, it cost us 10 pound 2 pound 10 shillings each as another mate came on the scene, we were not planning on registering this when we brought it, but 2 mates who were 6 months older than the other 2 decided they wanted to get it registered, so they brought our shares out & managed to get it registered. Later on Lee & myself brought a 1927 Rugby Durant for 15 pound with 6 months rego on it, so for the next 6 months we had a lot of fun in that car, I sold my share to Lee & he put a side valve V8 in it. I then brought a 1934 Ford sedan for 30 pound it was a very good car, wish I still had it, I sold it a couple of years later for 50 pound (the car is still on the road) & updated to a 1946 Ford Deluxe which I ended up writing it off.

My next car was a 1957 Ford Customline a beautiful car, I thrashed it & it never let me down. One time we were coming home from Wollongong, going up Mount Ousley when an FB Holden panel van came down the road sideways straight into the front of it, it broke the Holden in 2, while we were waiting for the tow truck a Japanese sports car came flying around the corner missed my mates 1939 Convertible Coupe & ran into the back of my car, both cars were written off mine was the only one repaired with a full spray job. I also had another 1934 Ford sedan that I was in the process of hot rodding, after several years of sitting around not doing anything with it I sold it & brought a coloured TV for \$700, that was it young family no more cars ha ha.

6 months later 2 of my mates showed up with a 1956 Ford Customline 90,000 Miles one owner lady who lived at Cronulla, got caught in the rain once & lost control of it was never driven in the rain after that, it was a beautiful straight car & I could not resist it, sold my ZC Fairlane & bought it, bought a daily driver Morris 1100 for Jan to drive. I took this car to Sawtell when we bought a Butcher Shop but it was sitting under a Carport getting salt spray over it so we sold it, no more cars.

I had a casual butcher who used to work for me who was in the Coffs Harbour Vintage car club & the desire came back, I bought a 1928 Ford Model a Roadster and later a 1936 Ford Phaeton which came to Ballina when we moved.

Since moving to Ballina we have owned 1957 Ford Customline, 1953 Ford Crestline Victoria, & currently have a 1956 Ford Fairlane Victoria a 1932 Ford 3 window Ford Coupe Hot rod. This does not include several Classic Harley Davidson motor bikes.

ALAN RIORDAN.....

P.S. I forgot about our Morris Mine Cooper S & our 1964 XM Falcon hardtop with a 302 V8 in it.

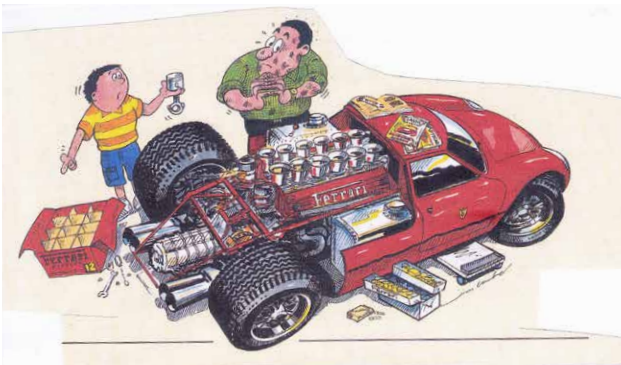

CLUB PLATES PLANNED CHANGES

As members will be aware, our club hosted the Department of Transport when they visited the region and ran talks on the Club Plates Scheme and provided answers to questions from the floor about specific issues and complying with the rules.

They did say they felt our club was complying with the requirements better than many clubs around the state which is a compliment to our Club Plates Registrar Santo. One issue that arose for Santo was the requirement that the cars are original and he has been signing his approval but was not sighting the cars individually. Our Club's requirement for a Pink Slip only really tests the cars safety and road worthiness but not its originality.

As a result of discussions at a recent meeting, our club has set up a Club Plates Committee to consider these issues. That committee and Executive held a meeting recently to decide on improving our system. Originally we thought the committee members could inspect cars but that places a lot of time and travel on them and was not really workable and also would be unworkable as to what is original on every make and model of car on club plates in our club.

The solution from that meeting was to put that responsibility on the members to provide a statement and three photos of their car as part

of the Club's Historic Plates Scheme. The Club will require members to submit three photos to the Club as part of the process and these will be kept on the Club's website but will be password protected to just Committee members. The photos are to be taken looking at the engine bay, a three quarter shot coving the front and the side and a rear shot. These can be done on most phones and sent to the Club before the Registration Day, usually in December. The website is being looked at to see if it has the capacity to do this. Also there will be sample photos to give members an idea of the pictures required. If there are problems, ask the grandkids for assistance! There will be more on this as the system is put in place over the next month. The forms have been developed so can be loaded to the Club website in preparation.

The Club Plates Scheme is a great benefit to our members so please try to comply with the rules to keep our club name respected and keep the Department of Transport happy with scheme as well as local Police. Any concerns over members breaching the rules can be passed on to the Committee and members of the Plates Committee can look at the issue.

Lindsay Smith

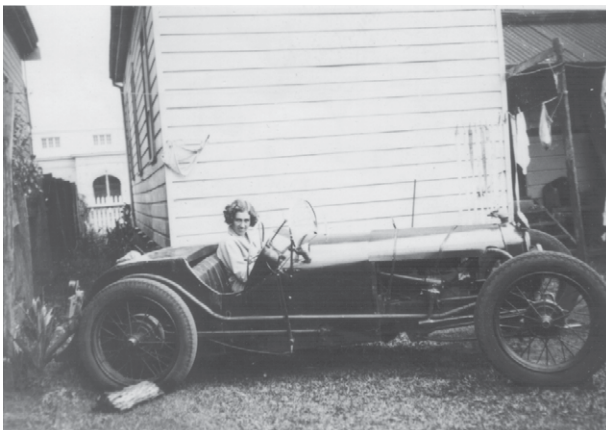
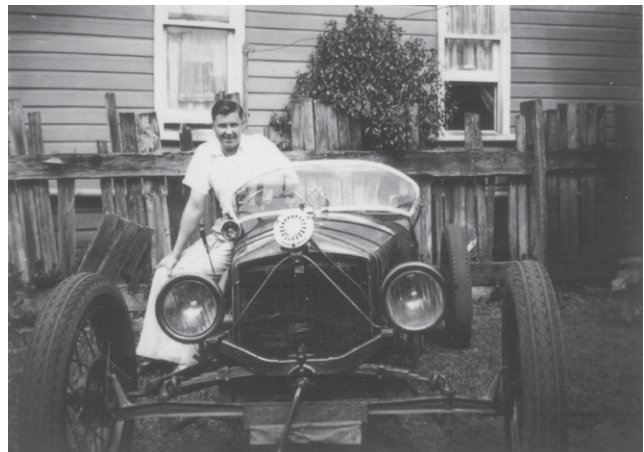
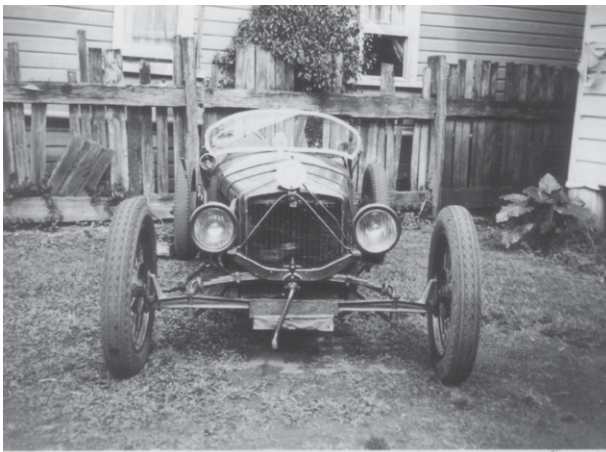

Ford Speedster with Frontenac cylinder head built by Bruce Watson senior in the mid 1930s.

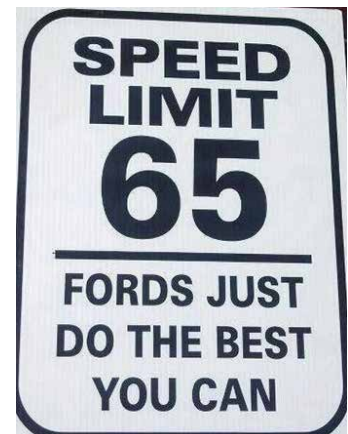

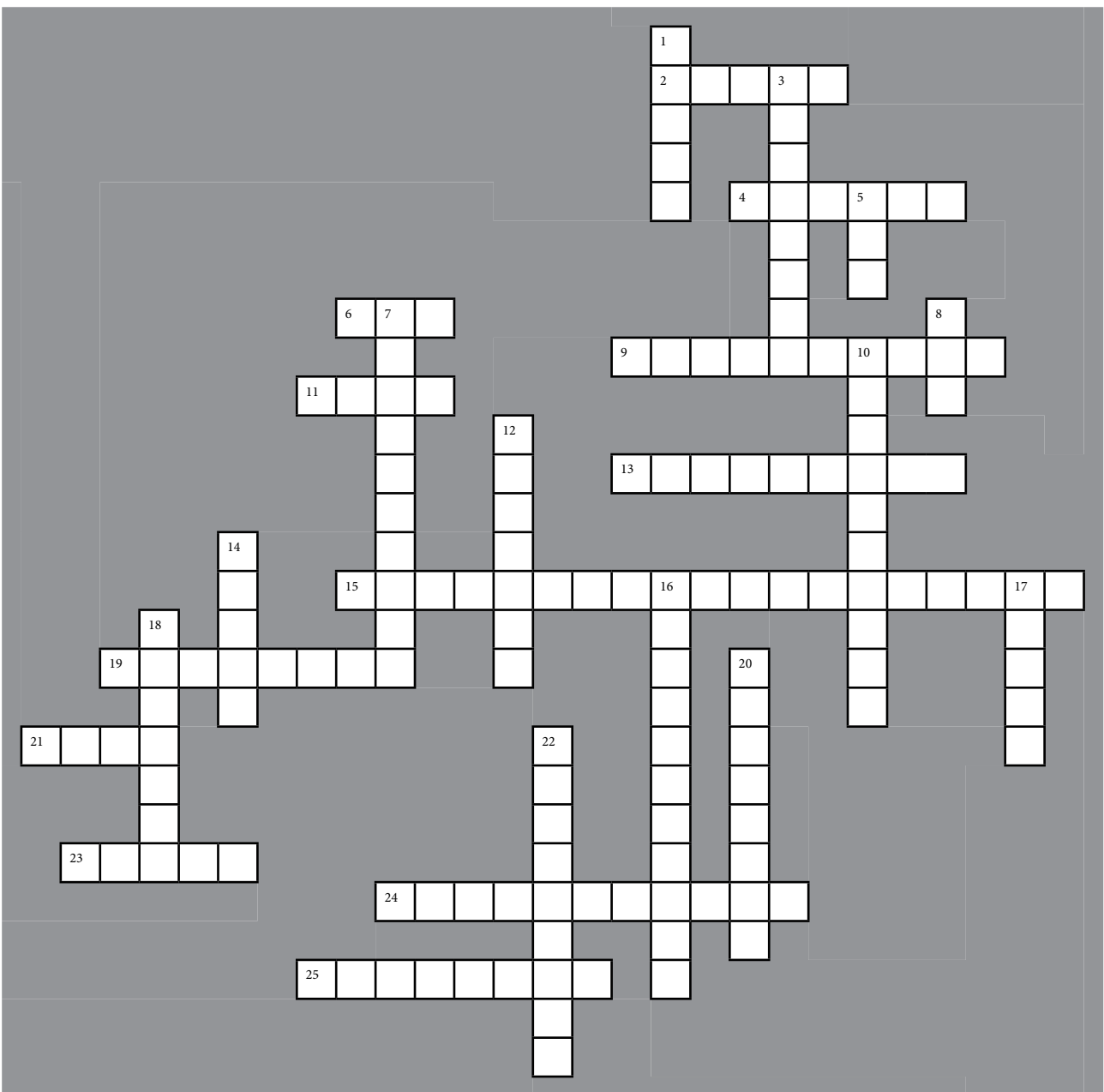

Across

- 2. What animal is on the Porsche logo
- 4. "Herbie" who starred in the 1969 Disney film was what type of Volkswagen model
- 6. The logo of which car manufactured features a circle divided into four sections of alternative white and blue
- 9. Who owns Ducati
- 11. Who made the first car in the world
- 13. Which element, with atomic number 46, is commonly found in catalytic converters
- 15. What does the abbreviation SUV stand for
- 19. Which Land Rover model is their famous off-road vehicle first introduced in 1983
- 21. How many rings are in the Audi logo
- 23. 1 in 4 cars on the UK road where made in what country
- 24. What is the name of a car with a roof that can be opened or taken off for an open-air drive
- 25. What fuel do electric cars run on

Down

- 1. How many wheels does a Robin Reliant have
- 3. What did Jaguar manufacture before they began to make automobiles
- 5. Most sports cars are typically designed with how many seats
- 7. Which car brand does Mr Bean drive
- 8. What colour were all Ferrari cars originally
- 10. What liquid substances, invented in 1926, is used in a car's cooling system
- 12. What's the most expensive car in the world
- 14. A group of cars is called a
- 16. What car badge features a golden bull
- 17. What is the name of a luxury division of Toyota
- 18. What kind of car inspired Ferruccio Lamborghini to start his own automobile company
- 20. In the UK, road signs depicting warnings and hazards are depicted by which 2D shape
- 22. Which Stephen King film details the horrors of a possessed Plymouth Fury

CLUB RUN RECIPE CRAIG'S FAMOUS RASPBERRY WHITE CHOCOLATE CHEESECAKE



- 1 packet + 4 scotch finger biscuits
- 90g unsalted butter (melted)
- 500g Philadelphia cream cheese (softened)
- 220g white chocolate (save some for garnishing over raspberries)
- ¾ cup of caster sugar
- 1 lemon (for rind and juice)
- 1 cup thickened cream
- 4 level teaspoons of gelatine dissolved into ¼ cup boiling water (add when cool)
- 2 punnets raspberries (cut in halves) save ½ punnet for garnishing

Crush scotch finger biscuits and add melted butter and press into a 240mm greased springform pan to form base, place in fridge to set. Boil water, add gelatine and allow to cool. Slowly melt white chocolate in microwave. Beat the softened cream cheese, sugar and lemon juice and rind until smooth. Add raspberries to mixture and fold in with wooden spoon. Remove base from fridge and pour mixture in. Put cheesecake back into fridge to set for 3 hours. Before serving, slice remaining ½ punnet raspberries in halves and place in a pattern on top and finely grate white chocolate blocks over for garnishing.

BLOODY BRILLIANT. NOW GET STUCK IN



Contribution from Craig Blackburn. Craig and wife Judy visit Ballina once a year. Craig raced bikes for Honda, Suzuki, Kawasaki, and Yamaha from 1976 to 1981. He raced in three Castrol 6 hrs, six Bathurst (1980, 3 place, 750 production race), two races in Canberra and one race at Surfers Paradise International Raceway. He had a total of 15 crashes with no broken bones. Craig still rides a BMW and a 955 Triumph Daytona around South Sydney.

TECHNICAL

CAR COOLING SYSTEM

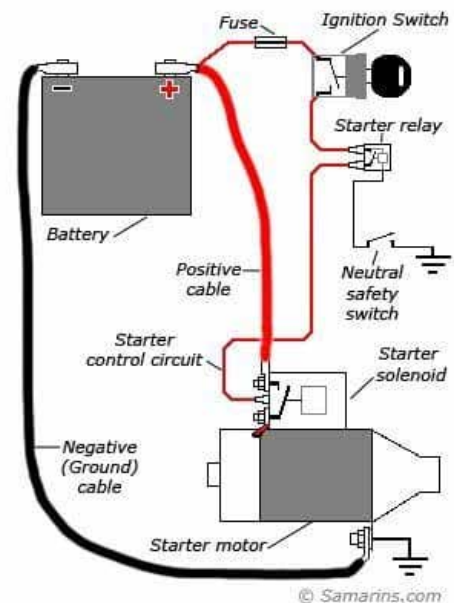
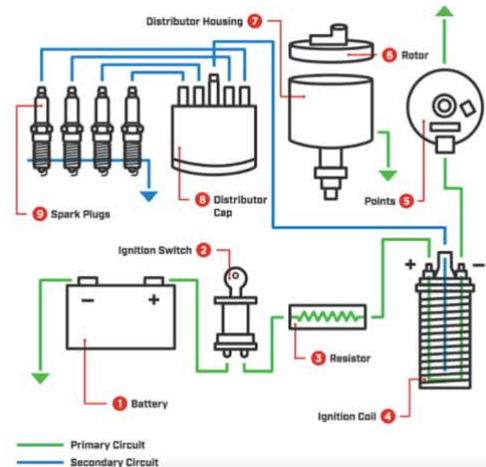
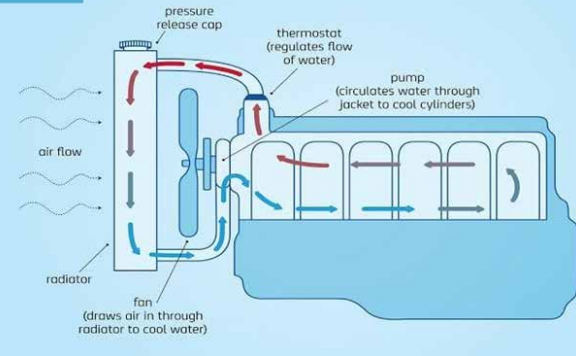

- Across
- 1. Three 3. Sidecars 5. Two 7. Mini/Cooper 8. Red Down
 - 2. Horse 4. Beetle 6. BMW 9. Volkswagen 11. Benz
 - 13. Palladium 15. Sport utility vehicle 19. Defender
 - 21. Four 23. China 24. Convertible 25. Electric
 - 10. Antfreeze 12. Bugatti 14. Fleet 16. Lamborghini
 - 17. Lexus 18. Ferrari 20. Triangle 22. Catherine

CROSSWORD ANSWERS

DATES FOR YOUR DIARY

September 9th
 Summerland House breakfast

October 7th
 Summerland House breakfast

November 11th
 Summerland House breakfast

December 1st (Friday)
 Christmas Function - venue TBA but possibly
 Che Bon as it has a fixed price meal.

**FROM THE ARCHIVE
 THE ORIGINAL NEWSLETTER**

BALLINA DISTRICTS VEHICLE RESTORERS' CLUB

"THE CARRIER PIGEON"

JANUARY 1981

"Members",

It is your steering committee's intention to produce this brief note immediately after general meetings and to mail it to all financial members. In this way, timely information will get to all. As you will see the newsheet can be prepared and distributed quickly without the hassles and delays in producing a magazine.

The note will be limited to one foolscap page. It will contain a brief summary of information made available and decisions taken at the last meeting, club's bank balance, a list of new members and significant news about existing members, full details about immediately forthcoming events, dates of later events and members' ads (for sale, wanted and for exchange).

Here goes.

The second meeting to form the Club was held at Ballina Golf Club on Wed Jan. 21, 1981. There were 23 persons present.

Preliminary decisions taken for incorporation in the Club's constitution were:

- that the Club be known as the Ballina Districts Vehicle Restorers' Club.
- that there be only one category of member; eligibility to be defined in terms of interest in vehicle restoration and preservation not ownership of a vehicle; membership to be on a family basis.
- that vehicles manufactured up to 31.12.55 be eligible to enter club events.
- that club plates (when and if we receive approval to issue them) be available to members with cars eligible under rules laid down by Department of Motor Transport (i.e. for cars up to a date in the mid 40's, we think).

Geoff Wiseman reported a bank balance of \$70 (14 x \$5 donations; no expenses paid).

The next general meeting will be at Ballina Golf Club at 8.00 p.m. on 4.3.81.

Our first family outing will be to Lennox Head on 22.2.81. You don't need a restored car. Meet at the southern approach to Missingham Bridge in time to depart at 11.00 a.m. Take your own tucker (B-B-Q's available). Take cricket bats, footballs, etc. If you miss the convoy meet up with the rest near Lake Ainsworth just before the entrance to the fitness camp. Les Mahony will lead the convoy - if you want more information contact him on 86 2935.

The following outing will be to the Everglades on 22.3.81.

For those interested, swap meets are to be held at McKees Hill (NRVCC) on 1.3.81, Coffs Harbour 8.3.81, Dalby 21/22.3.81, Narrabri 29.3.81, Redcliffe 25/26.4.81 and Gympie 2/3.5.81.

For Sale: '27 Dodge Utility (complete and partly restored) \$650; '60 Rover 90 auto, at Tamworth (going and unregistered) \$700 - Les Mahony 86 2935.

If you have an ad, get it to the next meeting when it will be read out and then printed in the next edition.

Geoff Buggie,
 Chairman.

COPY THAT @ PROFSEC

249 River Street Ballina 6686 7006

This newsletter has been formatted and printed by Copy That @ Profsec.